

DIESEL GENERATOR SET

DG00730D5

400 – 230 V/728 kVA/50 Hz/Standby
Series 1600 – MTU 12V1600



Optional equipment and finishing shown. Standard may vary.

PRODUCT HIGHLIGHTS

// Benefits

- Industry-leading average load factor
- Low fuel consumption
- Emissions optimizations available
- High availability and reliability
- Outstanding load acceptance
- Long maintenance intervals

// Support

- Global product support offered

// Standards

- Engine-generator set is designed and manufactured in facilities certified to standards ISO 2008:9001
- Generator set complies to ISO 8528 and fullfills performance level G3
- Generator meets BS5000; NEMA MG 1; ISO; DIN EN and IEC standards
- NFPA 110

// Available optimizations

- Exhaust emission EU 97/68 EC Stage III A
- NEA Singapore for off road diesel engines (ORDE)
- ARAI Stg II
- Fuel optimized

// Wide Standard Scope of Supply

- 4P circuit breaker
- Island operation control panel
- Integrated fuel tank
- Industrial silencer (15 dB(A))
- Batteries & battery charger

// Complete range of accessories available

- Sound attenuated enclosure
- Fuel system accessories
- Control panel & ATS
- Range of additional electrical options

// Warranty

- Standard 36 months warranty after shipment

APPLICATION DATA^①

// Engine

Manufacturer	MTU
Model	12V1600G80F
Type	4-cycle
Arrangement	12V
Displacement: L	21
Bore: mm	122
Stroke: mm	150
Compression ratio	17.5
Rated rpm	1500
Engine governor	ECU 8
Gross power: kWm	634
Air cleaner	Dry

// Fuel System

Max. fuel flow: L/h	342
Fuel tank capacity: OPU (EPU) in L	740 (950)
Autonomy: h	7

// Fuel Consumption

	L/h
At 100% of power rating:	141.54

// Liquid Capacity

Total oil system: L	72.5
Total coolant capacity: L	99

// Generator

Generator brand	Mecc-Alte
Generator type	HM355B3
Insulation class	H-class
Bearing	single bearing
Enclosure	IP23 M
Voltage regulation	A.V.R. (electronic)
Exciting system	self-excited, brushless

// Electrical

Electric system volts DC	24
Number of batteries	2
Capacity: Ah	2x 75

// Air Requirements

Aspirating: m ³ /min	45
Cooling air flow: m ³ /s	11.7

// Exhaust System

Gas temp. (stack): °C	485
Gas volume at stack temp.: m ³ /min	120
Maximum allowable back pressure: kPa	15

// Cooling/Radiator System

Ambient capacity of radiator in OPU (EPU): °C	40 (35)
Pressure on rad. exhaust: kPa	0.2
Heat rejection to coolant: kW	255

① Technical data is for a fuel-optimized unit.

STANDARD AND OPTIONAL FEATURES

// System Ratings (kW/kVA)

	DG00730D5
	Standby operation
Voltage	400 V
Phase	Three phase
Hz	50
kWel*	582
kVA**	728
Rated AMPS	1051

* $\cos \phi = 1,0$

** $\cos \phi = 0,8$

Also available for following voltages 380V & 415V - for details please contact your local MTU Onsite Energy Dealer.

// Engine

- 4- strokes diesel engine
- Flywheel housing SAE 1
- Flywheel 14"
- Four-valve, overhead camshaft
- Piston cooling via oil spray nozzle
- Forged crankshaft & connecting rods
- Oil pan
- Lube oil circulation pump
- Dry exhaust manifolds
- Hot components and radiator guards
- Mobile components guards
- Lube oil filter

// Fuel system

- Fuel main filter
- Fuel pre-filter with water separator
- Common rail fuel injection
- Automatic fuel transfer pump
- Heavy-duty fuel pre-filter with water separator
- 3-way valve for fuel filling

// Generator

- 3-Phase, synchronous, brushless, self exciting, self regulating, self ventilating alternator
- IP23 M protection degree
- Insulation class H

// Control Panel & Electric Options

- Control and power electric panel, with measurements devices and controller
- Remote display
- ModBus connection to customer systems TCP/IP
- ATS (Automatic Transfer Switch)
- Expansion module for CAN communication
- Control version for synchronizing with mains without blackout
- Control version for parallel operation

STANDARD AND OPTIONAL FEATURES, CONTINUATION

// Circuit Breaker/Power Distribution

- 4 poles manual circuit breaker (motorized with DeepSea controllers)

// Starting/Charging System

- 24V electric system
- Starting batteries installed
- Pre-heating resistance/jacket water heater
- Battery charging alternator
- Battery disconnecter
- Battery charger

// Air Intake System

- Exhaust turbochargers
- Set of dry-type air filters with containment indicator
- Intercooler, integrated in radiator
- Heavy duty air filter with automatic dust evacuation

// Exhaust System

- Industrial silencer 15 pdB(A)
- Residential silencer 35 dB(A)

// Cooling System

- Coolant circulation pump
- Front type radiator for jacket water and charge aircooling circuit with integrated expansion tank
- Engine mounted fan drive

// Mounting System

- Mounted on steel base frame
- Resilient mounting of engine and generator
- Integrated fuel tank (level sensor and drain cap incl.)

// Enclosures

- Sound proof enclosure
- Socket box

// Documentation & Certifications

- Genset & component manuals
- Maintenance schedule
- CE-certification for EU
- Fluids and lubricants specification

WEIGHTS AND DIMENSIONS

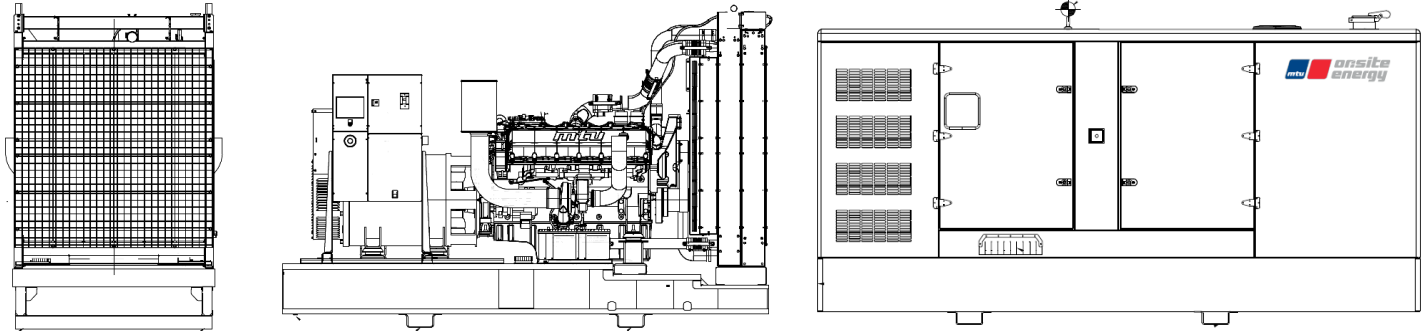

Drawing above for illustration purposes only, based on standard open and enclosed power 400 Volt engine-generator set. Lengths may vary with other voltages. Do not use for installation design. See website for unit specific template drawings.

System	Dimensions (LxWxH)	Weight (wet/with standard accessories)
Open Power Unit (OPU)	3.600 x 1.604 x 2.121 mm	4.671 kg
Enclosed Power Unit	5.000 x 2.100 x 2.369 mm	6.881 kg

Consult the factory for accurate weights and dimensions for your specific engine-generator set. Lengths may vary with other voltages. Do not use for installation design.

SOUND DATA

Unit Type	Standby full load and enclosed
Open Power Unit: dB(A)	on request
Enclosed Power Unit: dB(A)	74.5

Sound data is provided at 7m for 75% prime power.

RATING DEFINITIONS AND CONDITIONS

- // Standby ratings apply to installations served by a reliable utility source. The standby rating is applicable to varying loads for the duration of a power outage. No overload capability for this rating. Ratings are in accordance with ISO 8528-1, ISO 3046-1, BS 5514, AS 2789 and DIN 6271. Average load factor: < 85%, max. 500h/year.
- // Derating factor:
 - Altitude: Consult your local MTU Onsite Energy Power Generation distributor for altitude deratings.
 - Temperature: Consult your local MTU Onsite Energy Power Generation distributor for temperature deratings.

Rated power for reference conditions at 25°C and 100m above sea level.

Materials and specifications subject to change without notice.