

DIESEL GENERATOR SET

DG00033D5

400 – 230 V/30 kVA/50 Hz/Prime
400 – 230 V/33 kVA/50 Hz/Standby
IVECO – F32 AM 1A



Optional equipment and finishing shown. Standard may vary.

PRODUCT HIGHLIGHTS

// Benefits

- Low fuel consumption
- Emissions optimizations available
- High availability and reliability
- Outstanding load acceptance
- Long maintenance intervals

// Support

- Global product support offered

// Standards

- Engine-generator set is designed and manufactured in facilities certified to standards ISO 2008:9001
- Generator set complies to ISO 8528 and fullfills performance level G2
- Generator meets BS5000; NEMA MG 1; ISO; DIN EN and IEC standards
- NFPA 110

// Available emissions optimizations

- Exhaust emission EU 97/68 EC Stage III A

// Wide Standard Scope of Supply

- 4P circuit breaker
- Island operation control panel
- Integrated fuel tank
- Industrial silencer (15 dB(A))
- Batteries & battery charger

// Complete range of accessories available

- Sound attenuated enclosure
- Fuel system accessories
- Control panel & ATS
- Range of additional electronical options

// Warranty

- Standard 36 months warranty after shipment

APPLICATION DATA

// Engine

Manufacturer	IVECO
Model	F32 AM 1A
Type	4-cycle
Arrangement	4-L
Displacement: L	3.2
Bore: mm	99
Stroke: mm	104
Compression ratio	17.1
Rated rpm	1500
Engine governor	mechanical
Gross power: kWm (prime/standby)	29/32
Air cleaner	Dry

// Fuel System

Fuel tank capacity: OPU (EPU) in L	120 (100)
Autonomy: h	18

// Fuel Consumption

	L/h
At standby power rating:	9.6
At 100% of power rating:	8.3
At 50% of power rating:	4.3

// Liquid Capacity

Total oil system: L	10.5
Total coolant capacity: L	19.27

// Generator

Generator brand	Mecc-Alte
Generator type	HM160C1N
Insulation class	H-class
Bearing	single bearing
Enclosure	IP23 M
Voltage regulation	A.V.R. (electronic)
Exciting system	self-excited, brushless

// Electrical

Electric system volts DC	12
Battery capacity: Ah	100

// Air Requirements^①

Aspirating: m ³ /h	112
Cooling air flow: m ³ /s	1.4

// Exhaust System

Gas temp. (stack) ^② : °C	400
Gas volume at stack temp. ^③ : kg/h	152
Maximum allowable back pressure: kPa	5

// Cooling/Radiator System

Ambient capacity of radiator: OPU (EPU) in °C	50 (40)
---	---------

① Technical data is for 100% power.

② Technical data is for prime power.

③ Technical data is for standby power.

STANDARD AND OPTIONAL FEATURES

// System Ratings (kW/kVA)

	DG00033D5	DG00033D5
	Prime operation	Standby operation
Voltage	400 V	400 V
Phase	Three phase	Three phase
Hz	50	50
kWel*	24	26.4
kVA**	30	33
Rated AMPS	43.3	47.6

* $\cos \phi = 1,0$

** $\cos \phi = 0,8$

Also available for following voltages 380V & 415V - for details please contact your local MTU Onsite Energy Dealer.

// Engine

- 4- strokes diesel engine
- Flywheel housing SAE 3
- Flywheel 11 1/2"
- Oil pan
- Lube oil circulation pump
- Lube oil filter
- Dry exhaust manifolds
- Hot components and radiator guards
- Mobile components guards
- Electronic engine regulator

// Fuel system

- Fuel filter with water-separator
- Direct fuel injection system
- Automatic fuel transfer pump
- Heavy-duty fuel pre-filter with water separator
- 3-way valve for fuel filling

// Generator

- 3-Phase, synchronos, brushless, self exciting, self regulating, self ventilating alternator
- IP23 M protection degree
- Insulation class H

// Control Panel & Electric Options

- Control and power electric panel, with measurements devices and contoller
- Remote display
- ModBus connection to customer systems TCP/IP
- ATS (Automatic Transfer Switch)
- Expansion module for CAN communication
- Control version for synchronizing with mains without blackout
- Control version for parallel operation

STANDARD AND OPTIONAL FEATURES, CONTINUATION

// Circuit Breaker/Power Distribution

- 4 poles manual circuit breaker
(motorized with DeepSea controllers)

// Starting/Charging System

- 12V electric system
- Starting batteries installed
- Pre-heating resistance/jacket water heater
- Battery charging alternator
- Battery disconnecter
- Battery charger

// Air Intake System

- Dry-type air filter
- Heavy duty air filter with automatic dust evacuation

// Exhaust System

- Industrial silencer 15 dB(A)
- Residential silencer 35 dB(A)

// Cooling System

- Coolant circulation pump
- Front type radiator for jacket water
- Engine mounted fan drive

// Mounting System

- Mounted on steel base frame
- Resilient mounting of engine and generator
- Integrated fuel tank (level sensor and drain cap incl.)

// Enclosures

- Sound proof enclosure
- Socket box

// Documentation & Certifications

- Genset & component manuals
- Maintenance schedule
- CE-certification for EU
- Fluids and lubricants specification

WEIGHTS AND DIMENSIONS

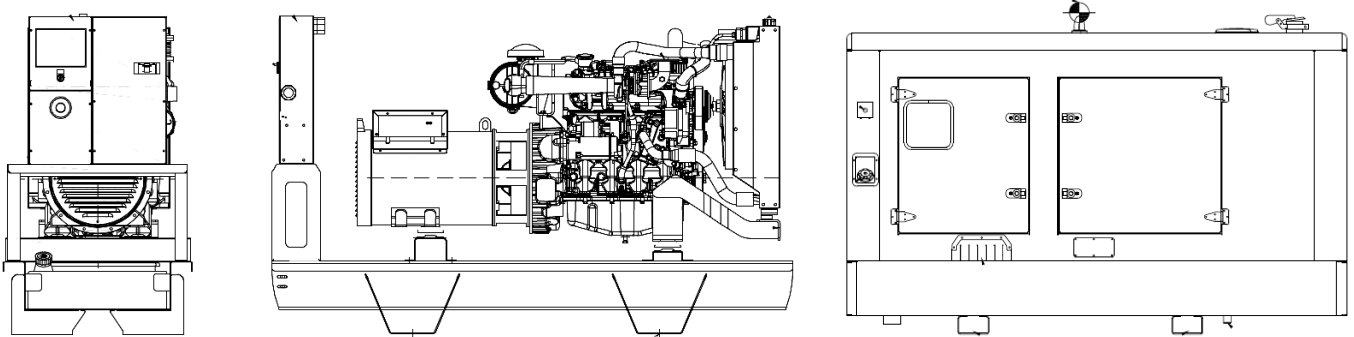

Drawing above for illustration purposes only, based on standard open and enclosed power 400 Volt engine-generator set. Lengths may vary with other voltages. Do not use for installation design. See website for unit specific template drawings.

System	Dimensions (LxWxH)	Weight (wet/with standard accessories)
Open Power Unit (OPU)	1.850 x 780 x 1.500 mm	661 kg
Enclosed Power Unit	2.100 x 975 x 1.349 mm	991 kg

Consult the factory for accurate weights and dimensions for your specific engine-generator set. Lengths may vary with other voltages. Do not use for installation design.

SOUND DATA

Unit Type	Standby full load and enclosed
Open Power Unit: dB(A)	on request
Enclosed Power Unit: dB(A)	61.7

Sound data is provided at 7m for 75% prime power.

RATING DEFINITIONS AND CONDITIONS

- // Prime power ratings apply to installations where utility power is unavailable or unreliable. At varying load, the number of generator set operating hours is unlimited. A 10% overload capacity is available for one hour in twelve. Ratings are in accordance with ISO 8528-1, ISO 3046-1, BS 5514, AS 2789 and DIN 6271. Average load factor: < 75%.
- // Standby ratings apply to installations served by a reliable utility source. The standby rating is applicable to varying loads for the duration of a power outage. No overload capability for this rating. Ratings are in accordance with ISO 8528-1, ISO 3046-1, BS 5514, AS 2789 and DIN 6271. Average load factor: < 85%, max. 500h/year.
- // Derating factor:
 - Altitude: Consult your local MTU Onsite Energy Power Generation distributor for altitude deratings.
 - Temperature: Consult your local MTU Onsite Energy Power Generation distributor for temperature deratings.

Rated power for reference conditions at 25°C and 100m above sea level.

Materials and specifications subject to change without notice.